



ClearSpace-1  
Active Debris Removal

# Telecommunication Subsystem Design

Hannes Bartle

EE-584 Spacecraft Design and Systems  
Engineering

Lecture 7

3/11/2025

# Objectives

## In this lecture:

- System level view of spacecraft communication systems
- Subsystem design process
- Link budget analysis
- Rough-Order-of-Magnitude (ROM) intuition about certain metrics
- Lots of cool pictures of spacecrafts

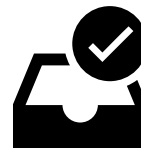

## Not in this lecture:

- Details of RF engineering (amplifier metrics, mixers, filters, etc)
- Details on Information Theory (Error correction codes)
- Higher level communication protocols (e.g. TCP/IP, CCSDS, CSP, ...)
- Ground Segment architectures (next week)
- On-board data communication interfaces (next week)

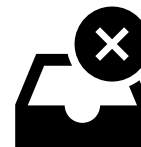

2020-2025: PhD Student Electromagnetics/Antenna Design



2020-2024: Telecom & Radar System Engineer



2017-2019: M.Sc. Electrical Engineering



2014-2017: B.Eng. Aerospace Engineering





Sentinel-6A  
SAR Sea-level Monitoring

# System Overview

Typical Earth Observation/Space Science architecture

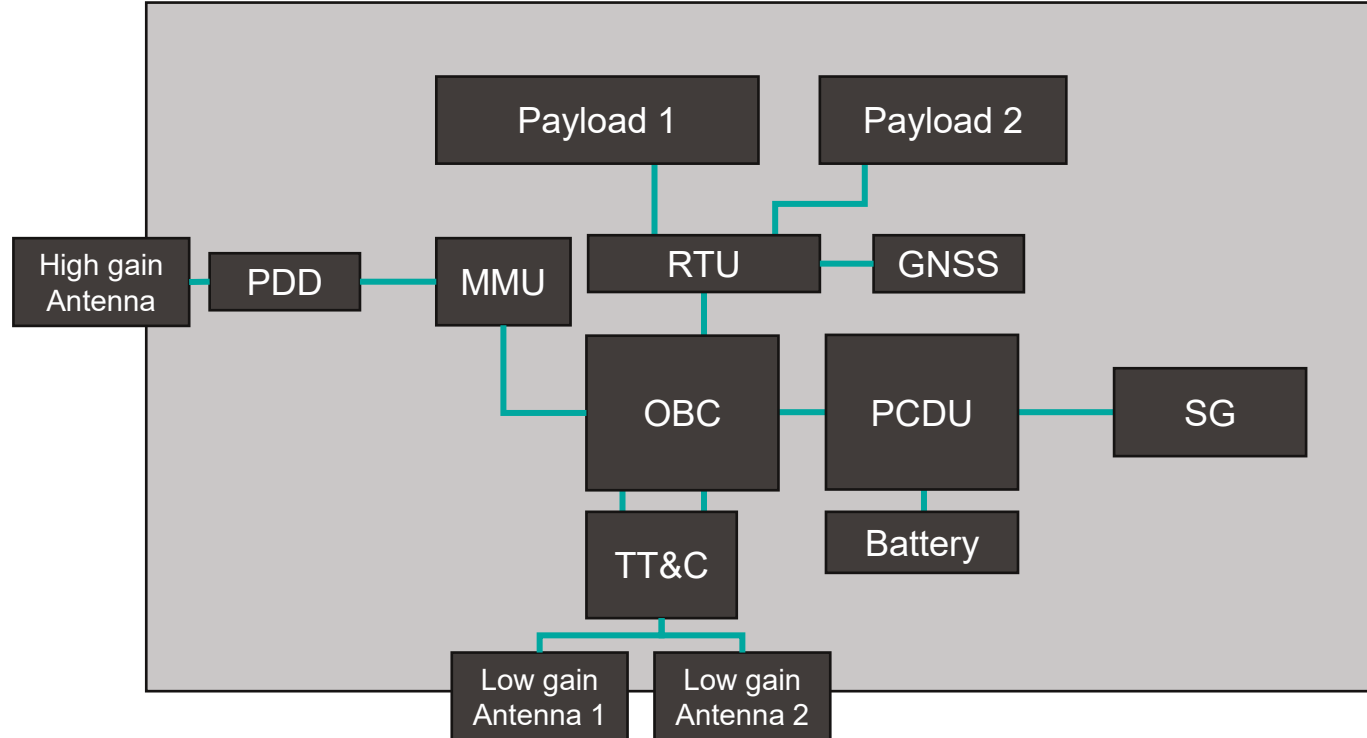

**OBC:** On-Board Computer  
**RTU:** Remote Terminal Unit  
**SG:** Solar Generator  
**PCDU:** Power Control and Distribution Unit  
**MMU:** Mass Memory Unit  
**GNSS:** Global Navigation Satellite System Receiver  
**TT&C:** Telemetry, Tracking and Control  
**PDD:** Payload Data Downlink

# Communication Systems

## Telemetry, Tracking & Control (TT&C)

- General commanding of the satellite
- Housekeeping and status information
  - Temperatures
  - Power states
  - Battery
  - Mechanisms states
  - etc
- Tracking
  - Tracking/Ranging functionality to determine position of spacecraft
  - Especially important when no GNSS available, i.e. interplanetary missions
- Without Tracking Capability: TM/TC

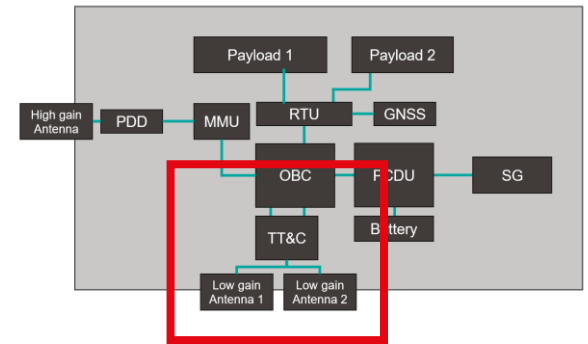

## Properties:

- Generally uses low gain antennas for quasi-isotropic coverage
- Relatively low data rates in kbps range
- Highly reliable hardware

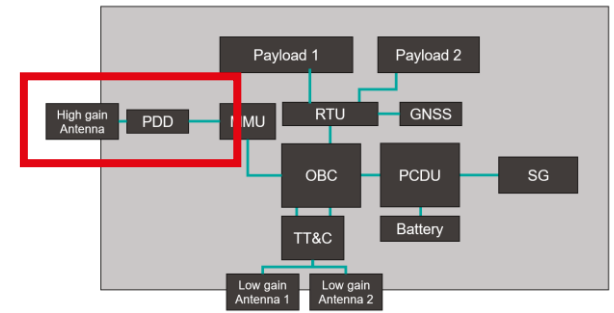

## Payload Data Downlink

- Downlink of large bulk data
  - Images
  - Video
  
- Either from mass memory or directly from payload
- High data rates
  - 10-100Mbps for CubeSat
  - 100-1000Mbps for SmallSats
  - >10Gbps for big earth observation missions
  
- Either traditional RF link or Optical (Laser)

# EO/Science Spacecraft System

## Sentinel-6A

- Synthetic Aperture Radar
- Sea-surface height measurements
- Measure the temperature and humidity in the troposphere and stratosphere



# EO/Science Spacecraft System

Flying Laptop

Technology Demonstration  
Multispectral Imagery



# EO/Science Spacecraft System

GOMX-4a

Multi-purpose imagery (land)  
Vegetation

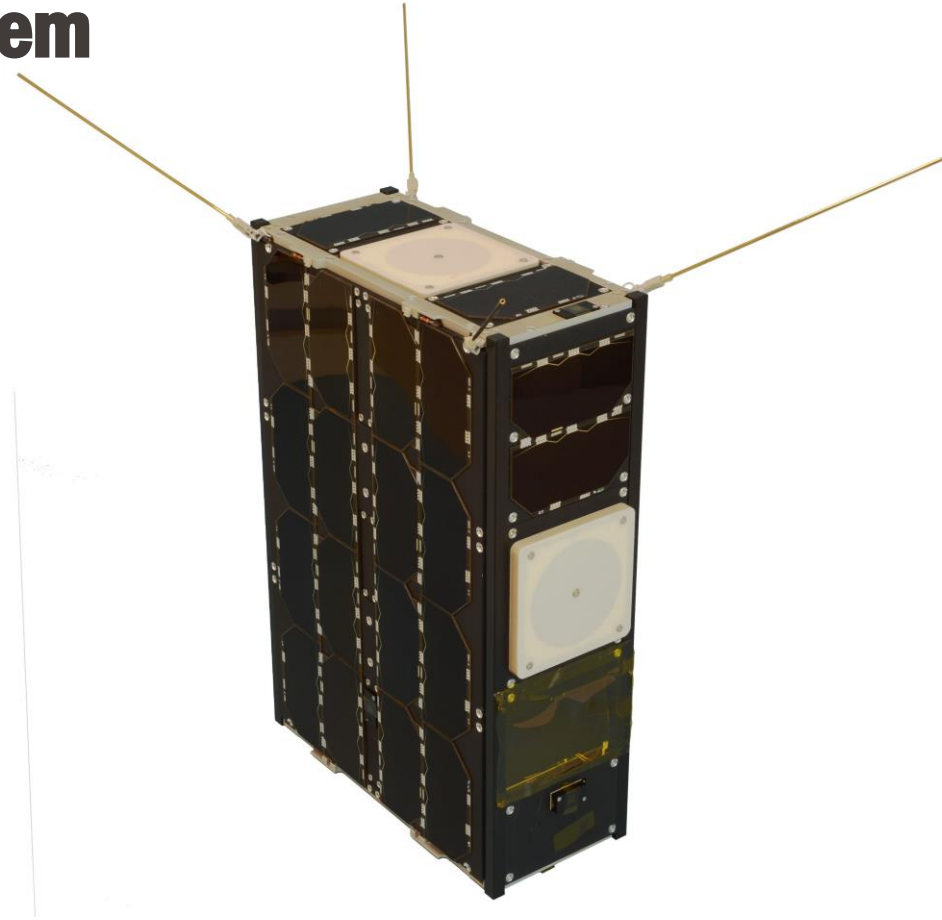

Typical Communication satellite architecture

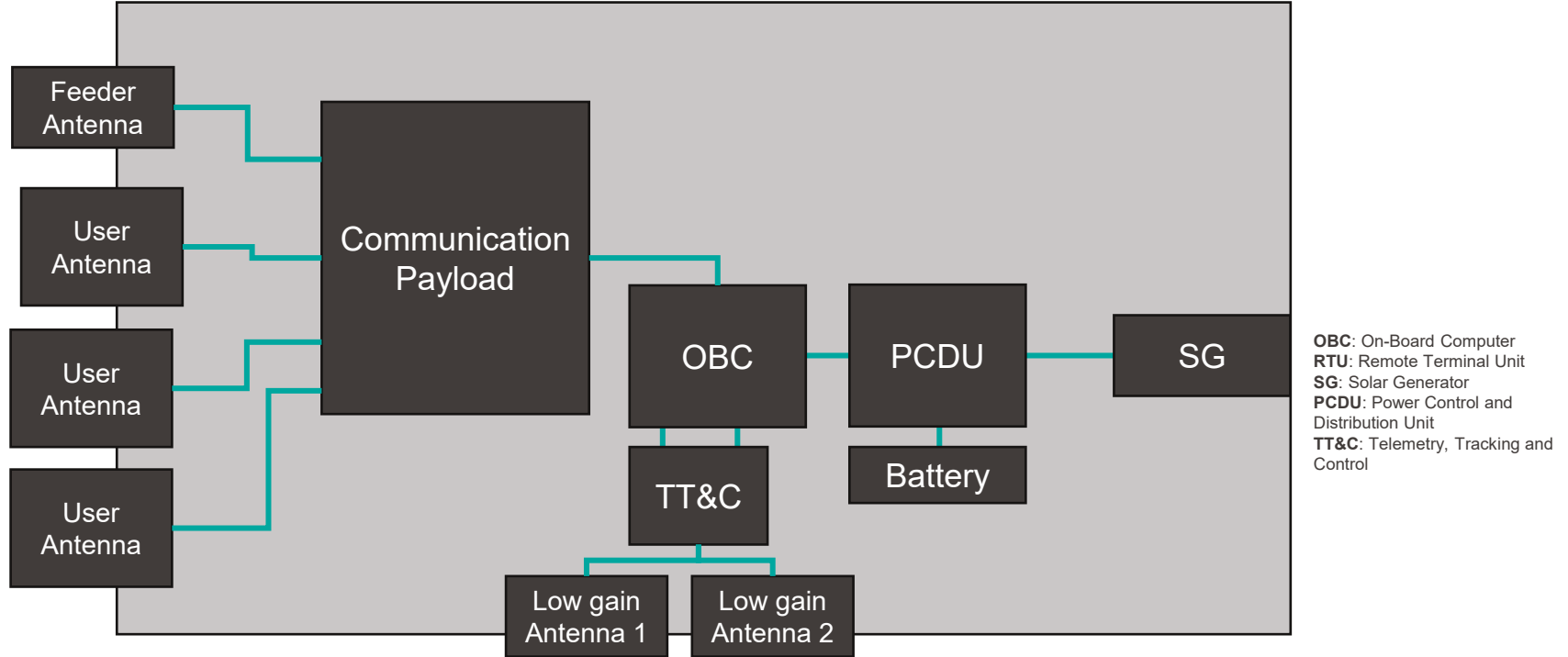

# Communication Satellite System

## Communication payload

- High performance Multiplexer/Demultiplexer/Router
- One or multiple feeder links
- Up to several hundred user beams
- Capacity 100-1000Gbps (single satellite)

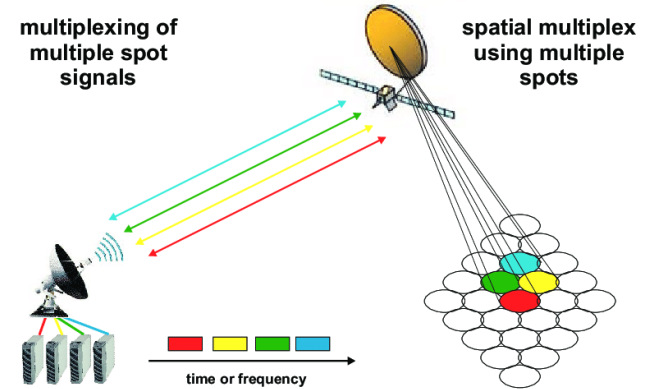
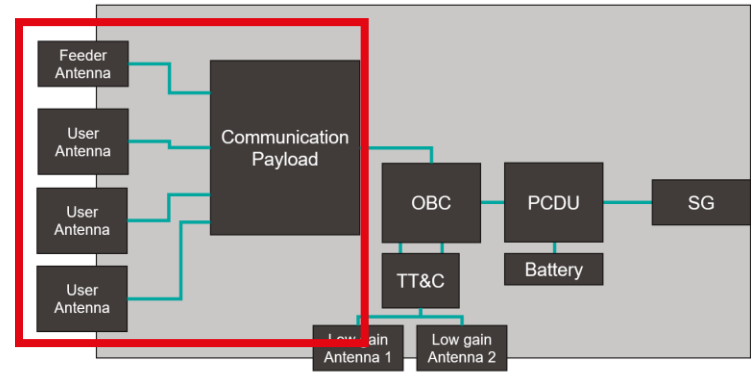

# Communication Satellite System

## NSS-12

- Ku-Band internet/TV Broadcast
- Several parabolic reflector antennas



# Communication Satellite System

## Starlink

- Ku/Ka-Band
- Intersatellite links
- Phased Array antennas

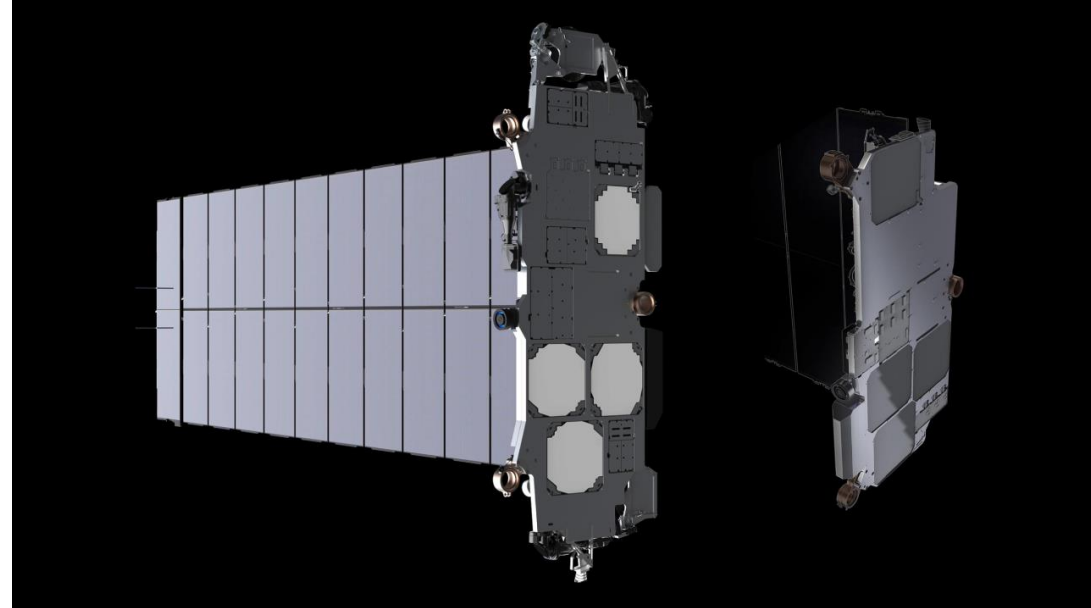

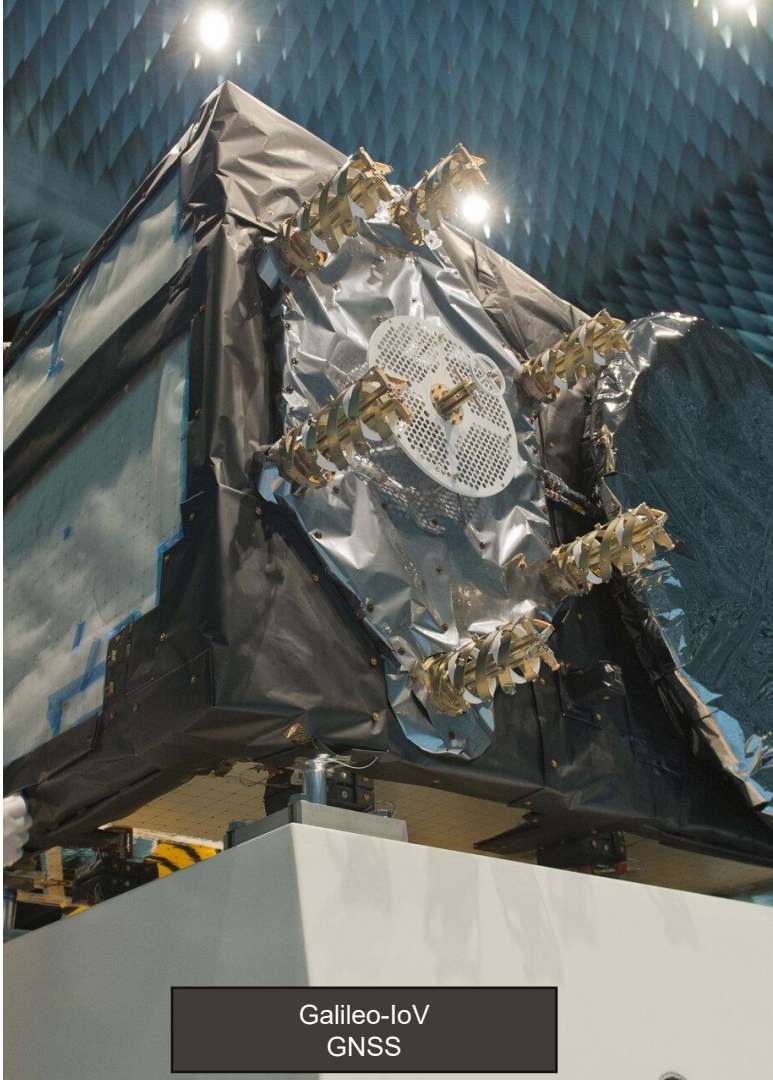

Galileo-IoV  
GNSS

# System Design Process

# Communication System Design Process

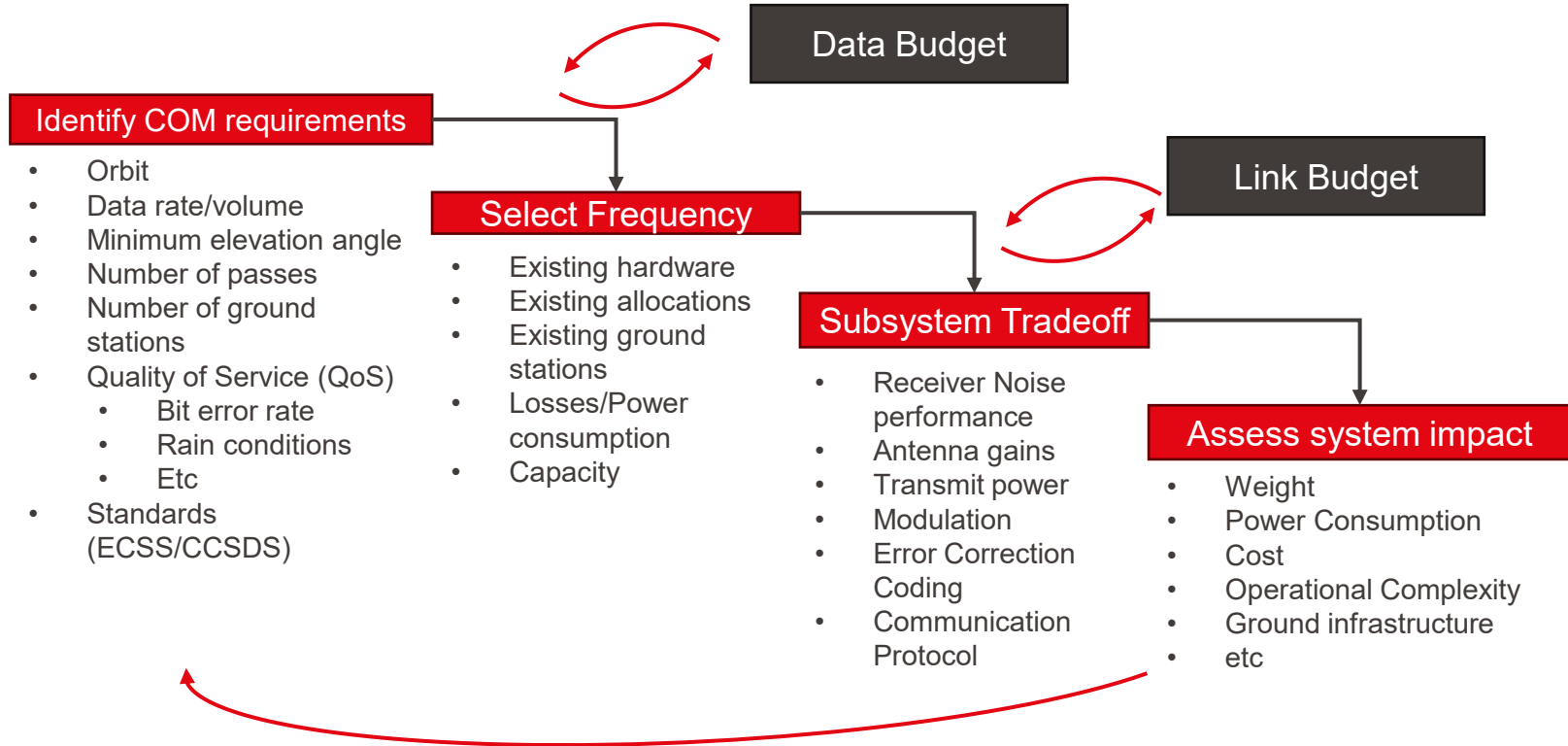



O3b Satellite  
Broadband Internet, Maritime

# System Data Budget

# Data Budget

- How much data is produced?
- How many ground stations are used?
- How often does a ground station pass occur?
- How long is a pass?
- What are the different mission phases?
- How much data storage is on board?

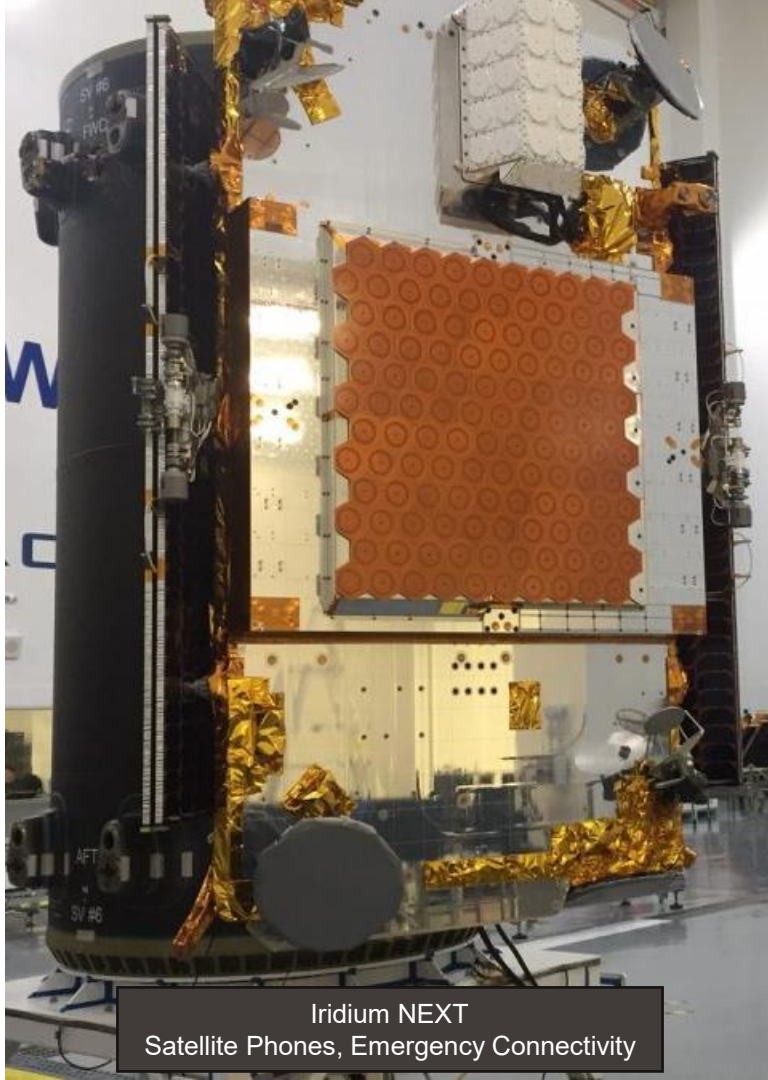

Iridium NEXT  
Satellite Phones, Emergency Connectivity

# Frequencies

- Frequency Spectrum coordinated by



- Frequencies are assigned to Services:
  - Earth Exploration Satellite Service (EESS)
  - Space Operation Satellite Service (SOS)
  - Space Research Service (SRS)
  - Amateur Satellite Service (ASS)
  - Etc

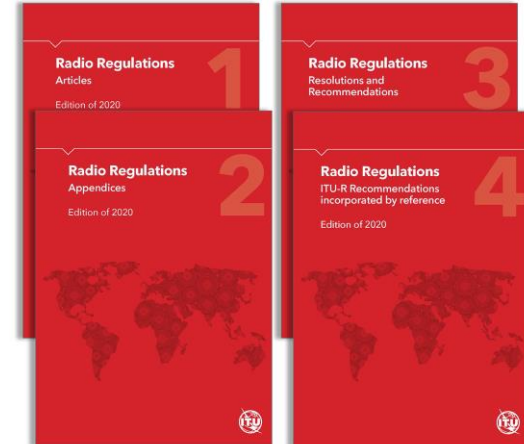

1 710-2 170 MHz

Allocation to services		
Region 1	Region 2	Region 3
<b>1 710-1 930</b>	FIXED MOBILE 5.384A 5.388A 5.388B 5.149 5.341 5.385 5.386 5.387 5.388	
<b>1 930-1 970</b> FIXED MOBILE 5.388A 5.388B  5.388	<b>1 930-1 970</b> FIXED MOBILE 5.388A 5.388B Mobile-satellite (Earth-to-space) 5.388	<b>1 930-1 970</b> FIXED MOBILE 5.388A 5.388B  5.388
<b>1 970-1 980</b>	FIXED MOBILE 5.388A 5.388B 5.388	
<b>1 980-2 010</b>	FIXED MOBILE MOBILE-SATELLITE (Earth-to-space) 5.351A 5.388 5.389A 5.389B 5.389F	
<b>2 010-2 025</b> FIXED MOBILE 5.388A 5.388B  5.388	<b>2 010-2 025</b> FIXED MOBILE MOBILE-SATELLITE (Earth-to-space)  5.388 5.389C 5.389E	<b>2 010-2 025</b> FIXED MOBILE 5.388A 5.388B  5.388
<b>2 025-2 110</b>	SPACE OPERATION (Earth-to-space) (space-to-space) EARTH EXPLORATION-SATELLITE (Earth-to-space) (space-to-space) FIXED MOBILE 5.391 SPACE RESEARCH (Earth-to-space) (space-to-space) 5.392	
<b>2 110-2 120</b>	FIXED MOBILE 5.388A 5.388B SPACE RESEARCH (deep space) (Earth-to-space) 5.388	
<b>2 120-2 160</b> FIXED MOBILE 5.388A 5.388B  5.388	<b>2 120-2 160</b> FIXED MOBILE 5.388A 5.388B Mobile-satellite (space-to-Earth) 5.388	<b>2 120-2 160</b> FIXED MOBILE 5.388A 5.388B  5.388
<b>2 160-2 170</b> FIXED MOBILE 5.388A 5.388B  5.388	<b>2 160-2 170</b> FIXED MOBILE MOBILE-SATELLITE (space-to-Earth)  5.388 5.389C 5.389E	<b>2 160-2 170</b> FIXED MOBILE 5.388A 5.388B  5.388

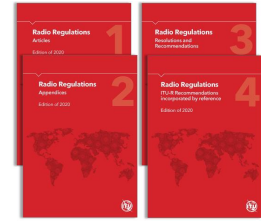

# Frequencies

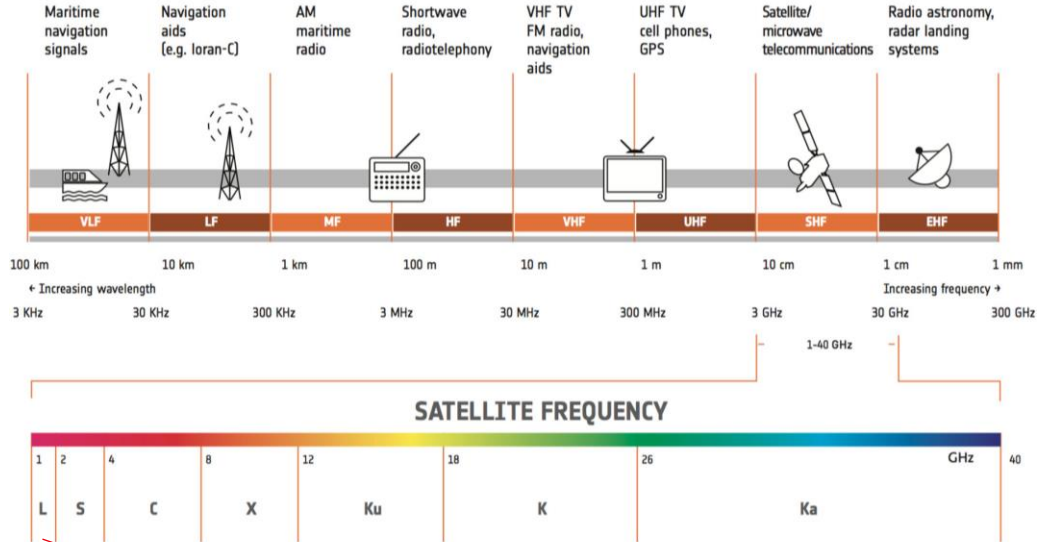

- GNSS
- Mobile Satellite Service
- Emergency Services

# Frequencies

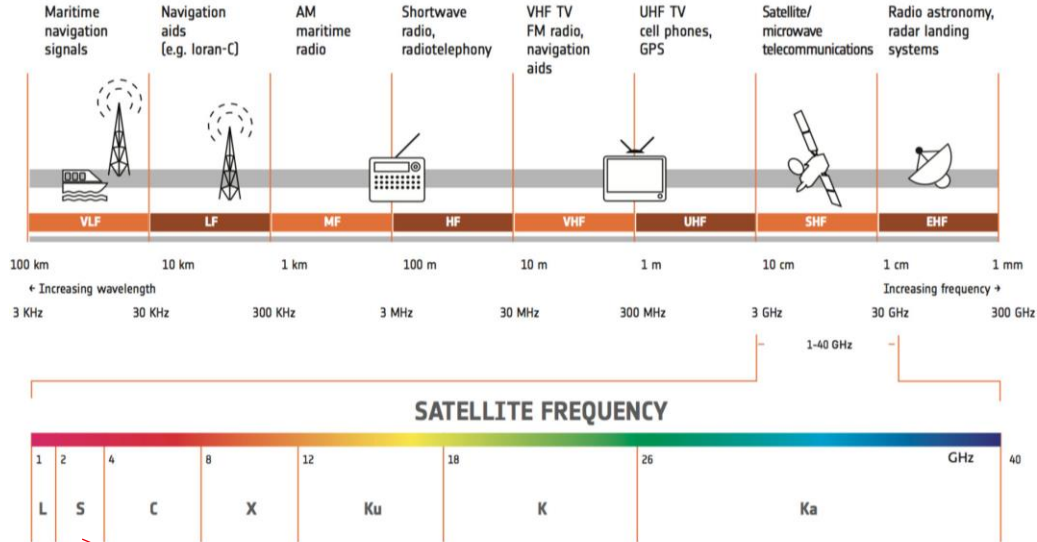

- LEO Spacecraft TM/TC
- Deep Space TT&C

# Frequencies

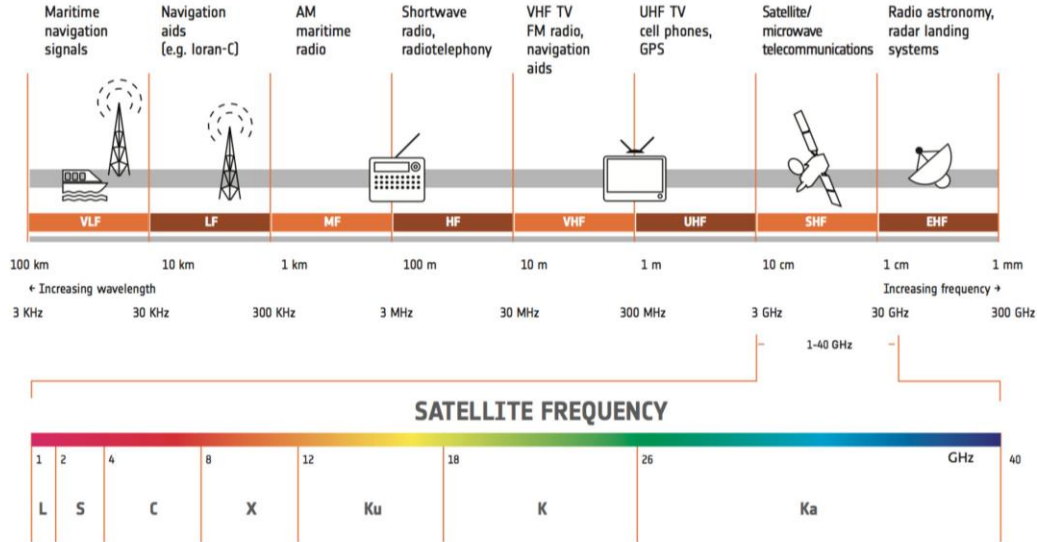

- Heritage GEO communication satellites
- 5G LEO constellations

# Frequencies

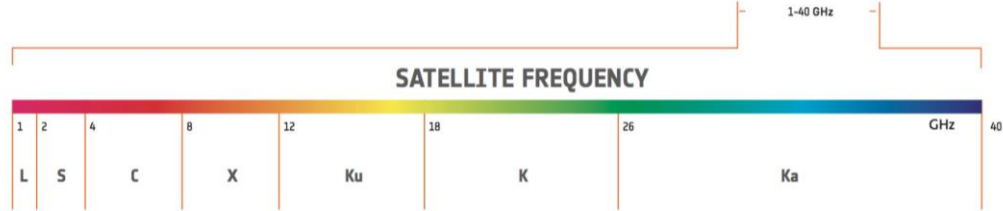
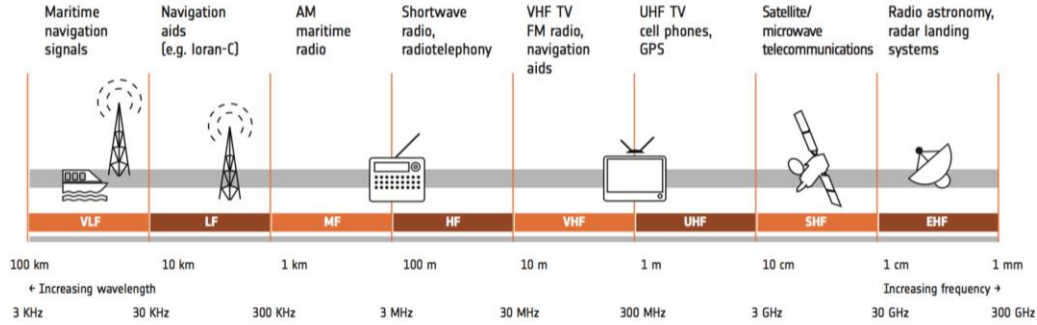

LEO Earth Observation Downlink

# Frequencies

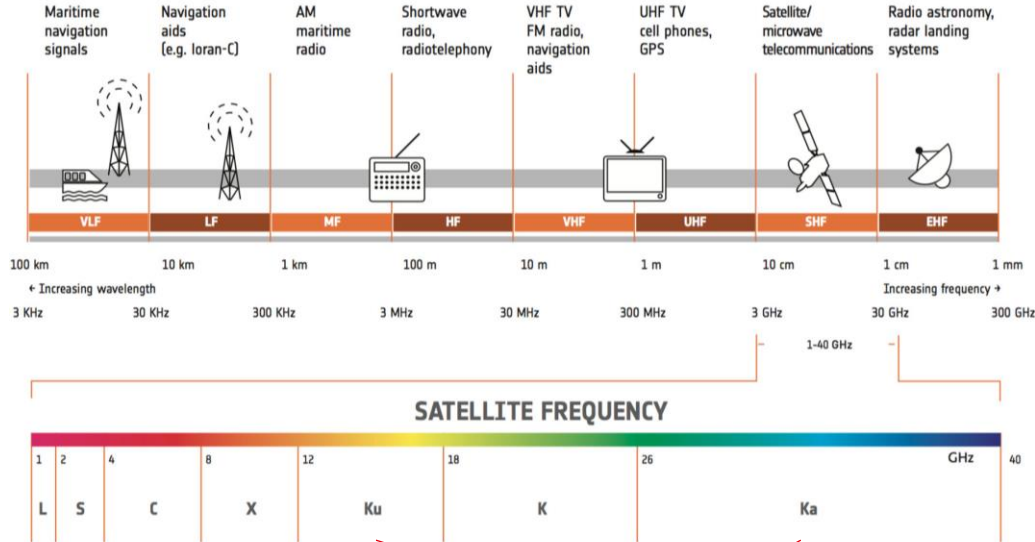

- LEO+GEO communication satellites
- Intersatellite links

# Frequencies

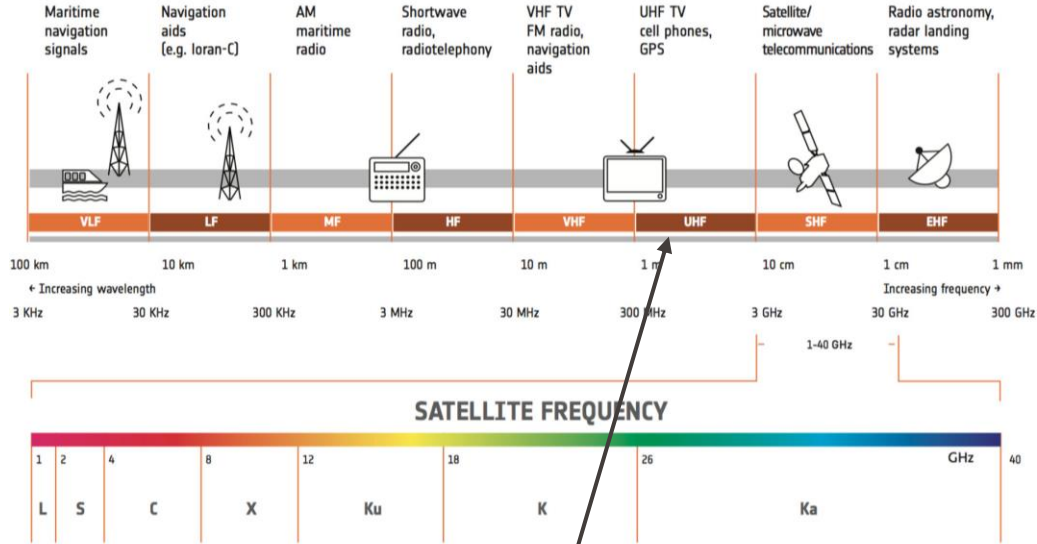

Most amateur satellites



Teleport  
Leuk/Loèche, Valais

# Link Budget

# Link Budget Equation

$$P_r =$$

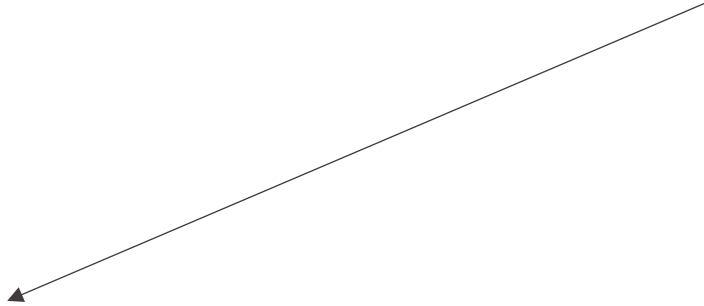

$$P_r = P_t - L_t + G_t - L_{\text{FSPL}} - L_{\text{atm}} - L_{\text{pol}} - L_{\text{rain}} + G_r$$

Attenuation due to spatial spreading of power

$$L_{\text{FSPL}} = \left( \frac{4\pi r}{\lambda} \right)^2$$

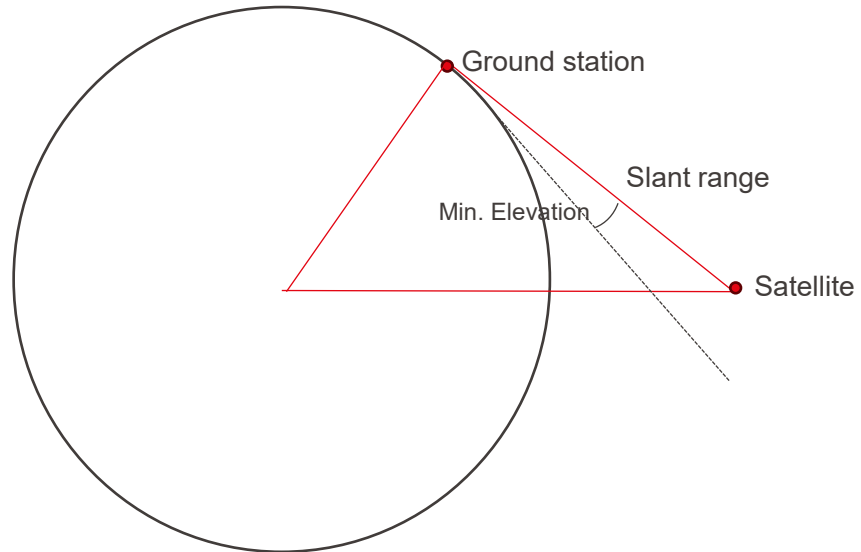
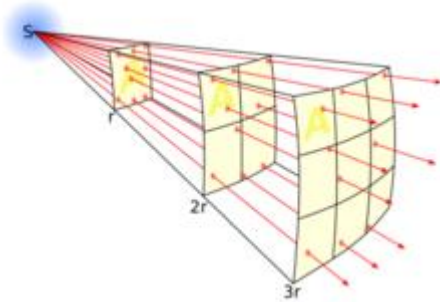

600km Orbit & 5deg min Elevation:

→ Max Slant range: 2330km

→ FSPL at 2.2GHz: **167dB**

# Antenna Gain

$$P_r = P_t - L_t + G_t - L_{\text{FSPL}} - L_{\text{atm}} - L_{\text{pol}} - L_{\text{rain}} + G_r$$

How **directive** is the antenna?  
How **efficient** is the antenna?

$$G = \eta D$$

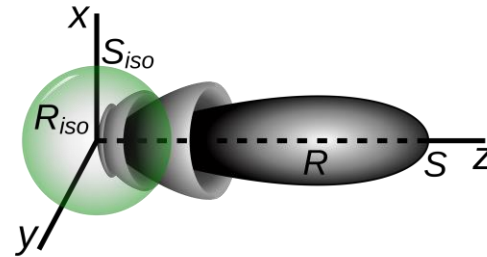

Quasi-isotropic: <3dBi  
Hemispherical: ~6dBi  
Directional: >10dBi

Parabolic dish antennas:

$$G = \eta \left( \frac{\pi d}{\lambda} \right)^2$$

Aperture Efficiency ~55-70%



$$P_r = P_t - L_t + G_t - L_{\text{FSPL}} - L_{\text{atm}} - L_{\text{pol}} - L_{\text{rain}} + G_r$$

Antennas have a specific polarization (Direction of E-field of radiated wave)

Linear:

- Potentially affected by Faraday rotation in the atmosphere
- Transmitter and Receiver antenna need to be aligned
  - Otherwise polarization loss

Circular:

- No Faraday rotation effect
- Spacecraft orientation (i.e. antenna alignment) doesn't matter

→ Most spacecraft antennas use circular polarization

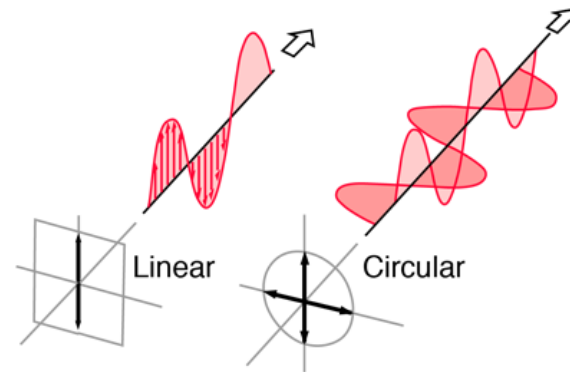

# Atmospheric Losses

$$P_r = P_t - L_t + G_t - L_{\text{FSPL}} - L_{\text{atm}} - L_{\text{pol}} - L_{\text{rain}} + G_r$$

Attenuation due to gases and humidity in atmosphere

→ Only relevant for high frequencies  
>20GHz

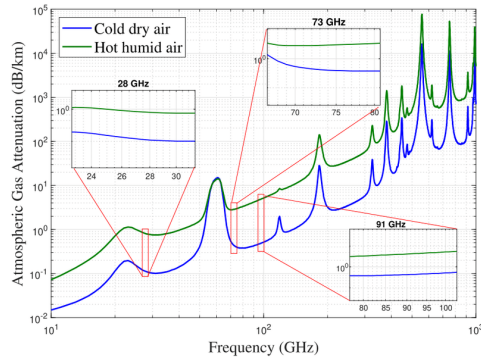

ITU Recommendation P.676-13

Attenuation due to rain

- Depends on GS location
- Depends on Service Availability (90%,95%,99%)

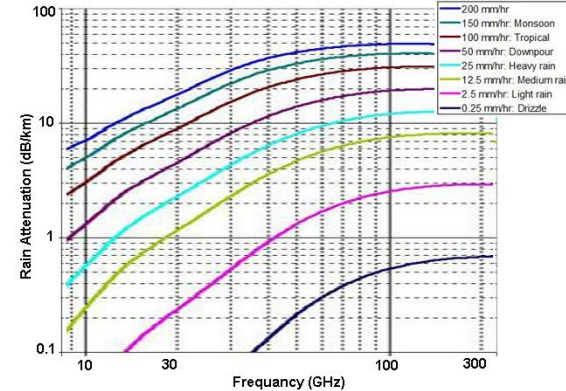

ITU Recommendation P.838-3

Observing a signal means introducing noise

$$N = k_B T_{sys} B$$

B: Bandwidth of receiver window

- Needs to be large enough to let all “useful” signal through
- Shouldn't be any larger as noise will be increased
- Dedicated filtering necessary at receiver

$T_{sys}$ : Equivalent System Noise Temperature

$k_B$ : Boltzmann's constant

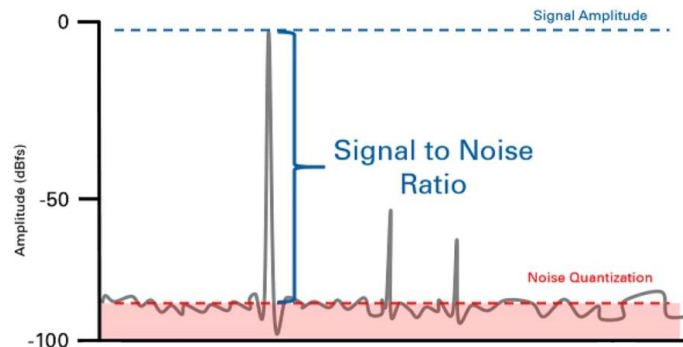

$$N = k_B T_{sys} B$$

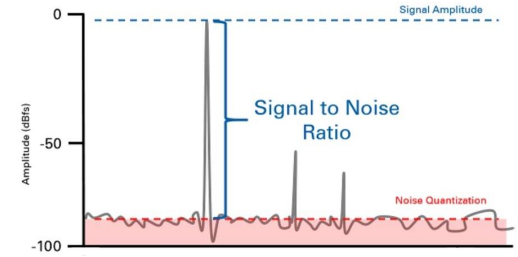

## System Noise Temperature

- Artificial metric to account for all components in the system that introduce noise
- Not a physical temperature
- Main components:
  - Antenna Temperature
  - Receiver chain
- Derived by Friis Noise Formula:

$$T_{sys} = T_{ant} + T_{cable} + T_{LNA} + \frac{T_{cable}}{G_{LNA}} + \frac{T_{Rx}}{G_{LNA}L_{cable}}$$

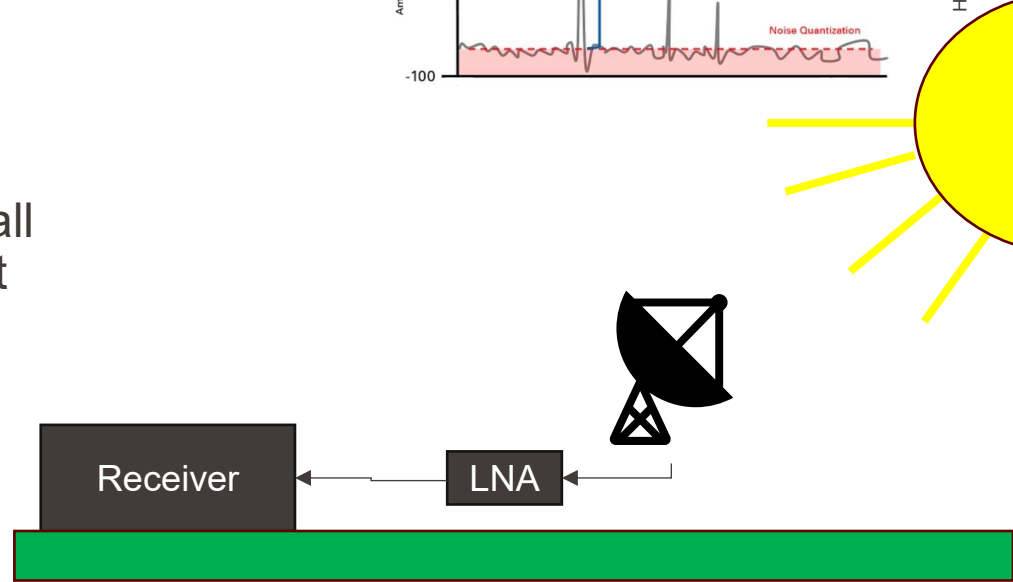

# Noise Example

$$T_{sys} = T_{ant} + T_{cable} + T_{LNA} + \frac{T_{cable}}{G_{LNA}} + \frac{T_{Rx}}{G_{LNA}L_{cable}}$$

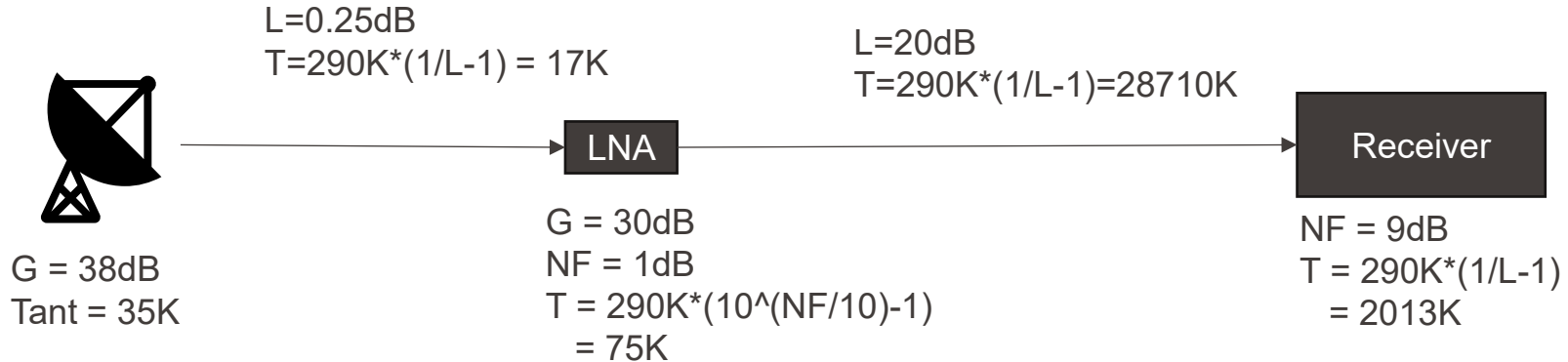

Resulting System Noise temperature:

$$T_{sys} = 340\text{K}$$

Combined with receiver antenna gain into the Receiver Figure of Merit (G/T):

$$G/T = 12.68\text{dB/K}$$

# Signal to Noise Ratio

SNR determines if data can be recovered or not

$$SNR = \frac{C}{N} = \frac{P_r}{N}$$

Energy per bit relative to the noise spectral density is more useful (independent of bandwidth B):

$$\frac{E_b}{N_0} = \frac{C}{N} \frac{B}{R} = \frac{P_r}{k_B T_{sys}} \frac{1}{R}$$

Different modulation schemes have different required  $E_b/N_0$  for a certain **Bit-Error-Rate**

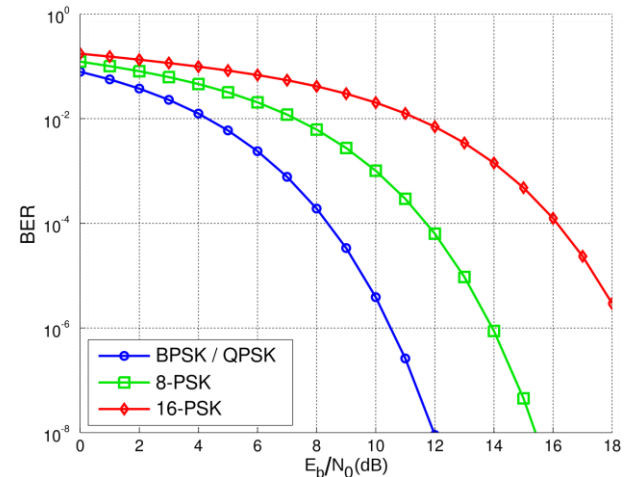
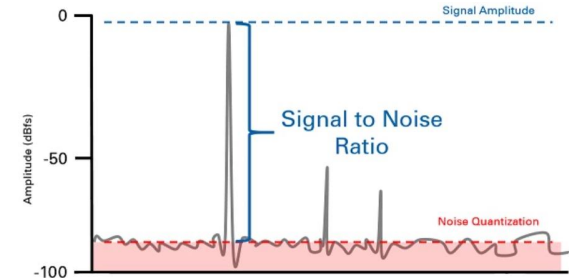

In order to send data, analog or digital, a RF carrier signal needs to be **modulated**:

- Amplitude
- Phase
- Frequency
- Combination of the above

- Higher order modulations use several states to encode more than one bit
- For the **same symbol rate** they achieve a **higher data rate**

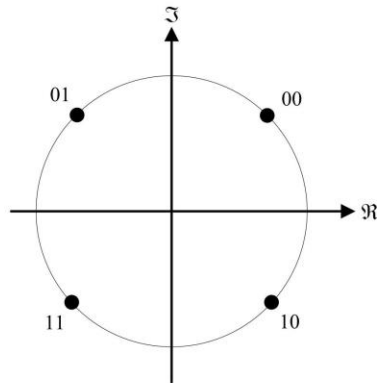

(a) QPSK

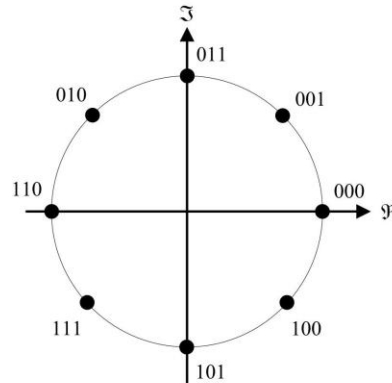

(b) 8-PSK

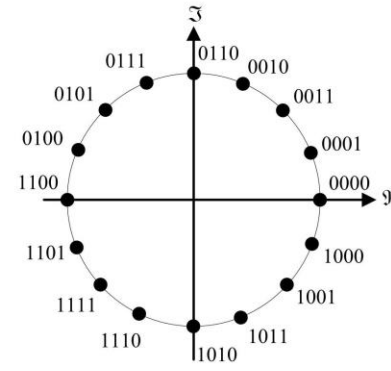

(c) 16-PSK

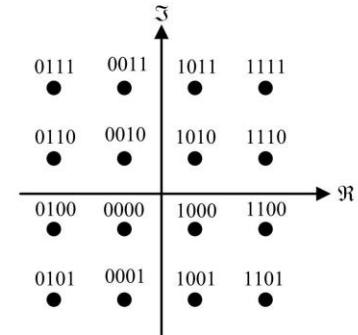

(d) 16-QAM

- How likely do we make mistake in receiving data?  
→ Bit-Error Rate
- Determines Quality of Service required for specific application

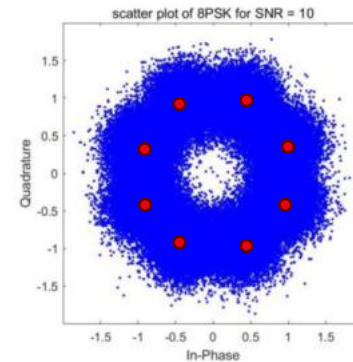
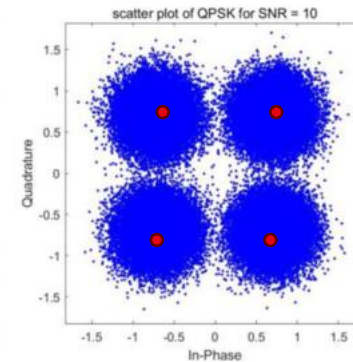
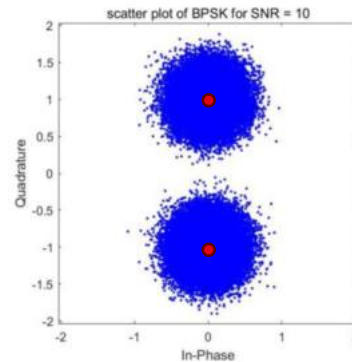
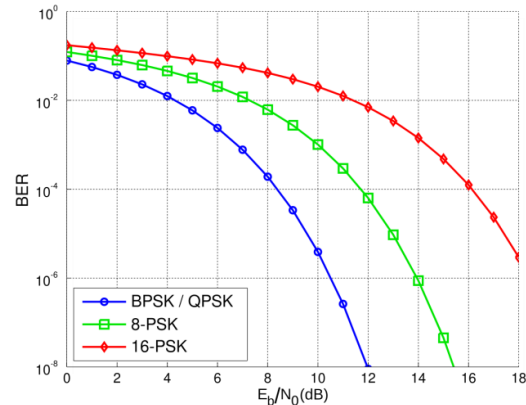

Modulation	$E_b/N_0$ for BER = $10^{-5}$ (dB)	Spectrum Utilization (bps/Hz)	Advantages	Disadvantages
BPSK	9.6	1.0	Good BER performance. Good use of spectrum.	Susceptible to phase disturbances.
DPSK	10.3	1.0	Not susceptible to phase disturbances.	Higher $E_b/N_0$ required.
QPSK	9.6	2.0	Excellent use of spectrum.	More susceptible to phase disturbances.
FSK	13.3	0.5	Not susceptible to phase disturbances.	Higher $E_b/N_0$ required. Poor use of spectrum.
8FSK	9.2	0.375	Good BER performance. Not susceptible to phase disturbances.	Poor use of spectrum.
BPSK and QPSK Plus R-1/2 Viterbi Decoding	4.4	0.5 and 1.0	Excellent BER performance.	Higher complexity. Reduced use of spectrum.
BPSK Plus RS and Viterbi Decoding	2.7	0.44	Best BER performance.	Most complex. Reduced use of spectrum.
8FSK Plus R-1/2 Viterbi Decoding	4.0	0.188	Excellent BER performance. Not susceptible to phase disturbances.	Poor use of spectrum. High complexity.
MSK	9.6	1.5	Low adjacent channel interference.	Higher complexity.
BPSK/PM ( $\Delta\phi = 1.0$ rad sinewave)	13.8	$\sim \frac{R}{2f_c}$	Carrier transmitted for Doppler measurement.	Requires extra power and bandwidth.

# Required $E_b/N_0$

- Different modulations have different required  $E_b/N_0$  for given BER
- Required  $E_b/N_0$  can be lowered by adding an **error correction code**
- Similar to parity bits/checksum
- Detects errors AND can correct some of them
- Better codes (lower  $E_b/N_0$ ) generally means **higher implementation complexity**
- FEC introduces overhead

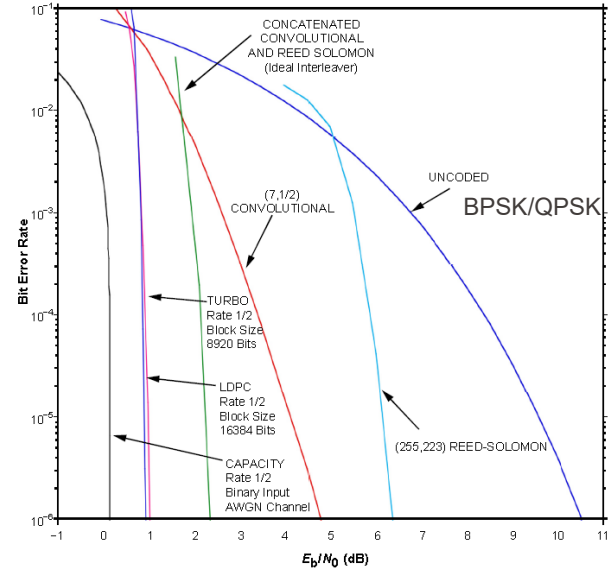

- Even if worst case estimates are used, parameters are randomly distributed
- Link margins ensure robust communication
- Commonly used margins:
  - Amateur Satellite: 10dB
  - TT&C for EO satellite: 3-6dB
  - Payload Downlink for EO satellite: 3dB



LEO sat observing Rolex Building, ChatGPT

# Link Budget Examples

# LEO Example

## Mission:

- Live video feed of EPFL Campus from LEO Orbit
- 400km orbit
- Ground Sample Distance (GSD) 1m
- 4K@60fps
- Use 1.7m dish on top of ELB building
- S-band TMTC
- X-band Payload Data Downlink



Berlin SpaceTech (BST) LEOS-50



$$\text{GSD} = \frac{dH}{F}$$

$$\begin{aligned} \text{GSD} &= 1\text{m} \\ \text{Pixel Size} &\sim 7\mu\text{m} \\ \rightarrow F &= 2.8\text{m} \end{aligned}$$

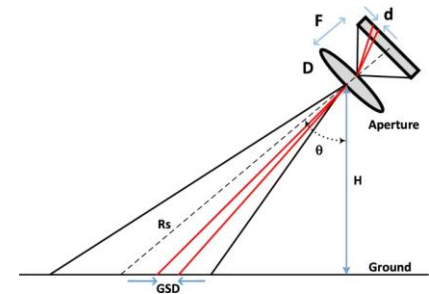

# LEO Example TMTC System

- Cold Redundant Transmitter
- Hot Redundant Receiver
- Diplexing filter splits TX/RX frequencies to avoid self interference
- Two quasi-isotropic antennas to maximize coverage when tumbling
- 3dB hybrid to split/combine signal between redundant antennas and redundant RX/TX pairs

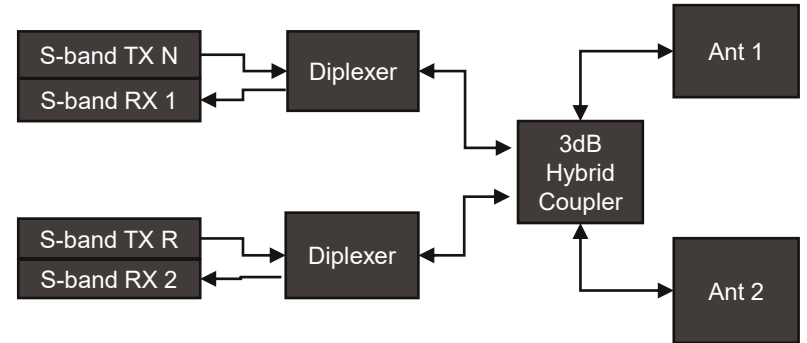

# LEO Example TMTC System



SSTRC300  
STT Systemtechnik GmbH



Turnstile Crossed-Dipole Antenna  
STT Systemtechnik GmbH

# LEO Example PDD System

- Cold Redundant chains
- Directive antennas

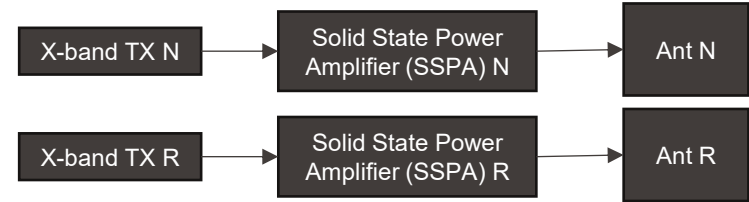

# LEO Example PDD System

XONOS  
Symlinks



X-band patch antenna array  
EnduroSat

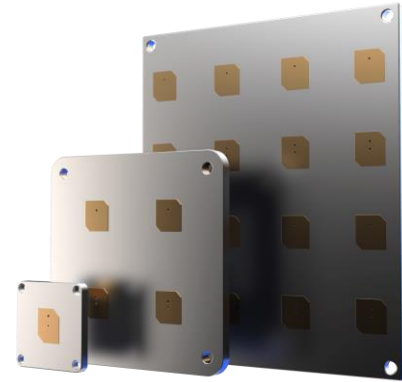

# LEO Example Data Budget

## TMTC Data budget

- Assuming only one contact per day (TMTC and PDD at the same time)
- 10min communication window
- Live camera is very tricky to operate and calibrate because of high resolution/frame rate
- 32kbps uplink
- 512kbps downlink

# LEO Example Data Budget

PDD Data budget

- 4k@60fps
- 12-bit colour resolution

Data generation rate:

$$3840 \times 2160 \times 12 \times 60 = 5.9 \text{ Gbps}$$

Live downlink means

→ Data generation rate = Useable downlink data rate

# LEO Example

- 600km Orbit
- 5deg min Elevation
- TT&C in S-band Up and Downlink
  - Uplink 32kbps
  - Downlink 512kbps
  - Quasi-isotropic coverage in case satellite is tumbling
- PDD in X-band
  - Downlink 5.9Gbps
  - Directional antenna, spacecraft steering towards ground

Excel Link Budget Table

## EuropaClipper

- Launched 14.10.2024
- Investigate Jupiter moon Europa's ice crust and subsurface water oceans
- Potential for life?

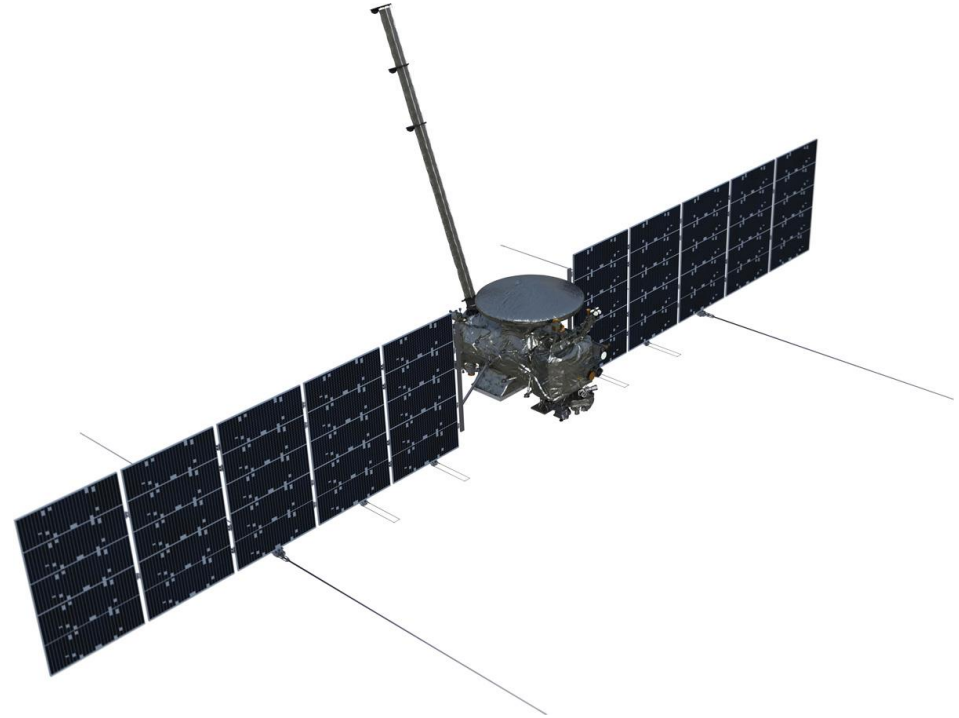

- X-band TMTTC system
  - 10bps (Emergency) to 100kbps (during Cruise)
  
- Ka-band Payload data system
  - 50kbps to 1Mbps
  
- All links with TurboCode
- Several Low gain, medium gain and high gain antennas

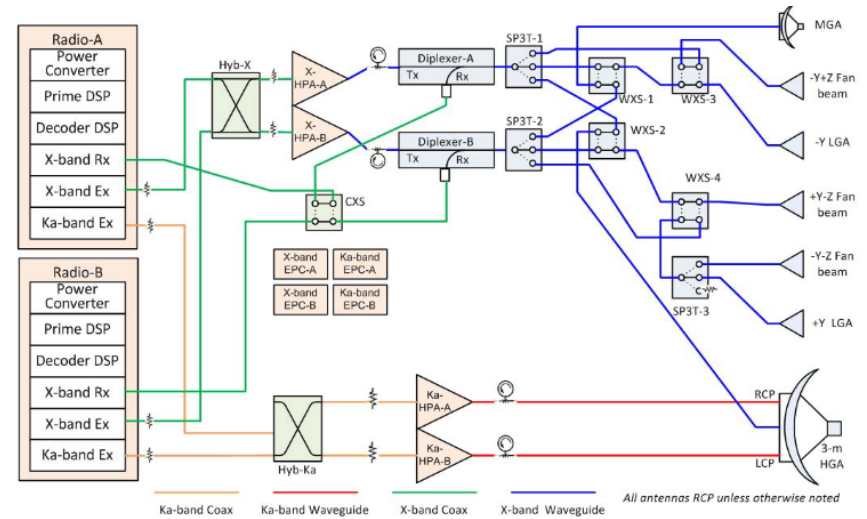
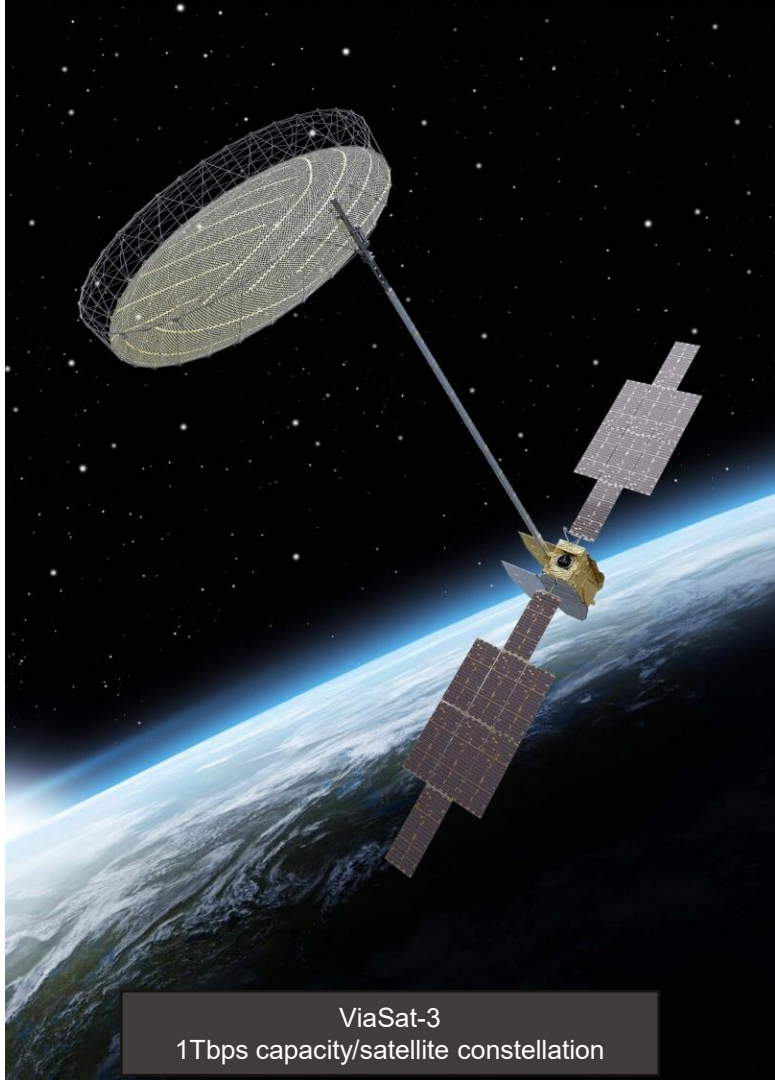

Fig. 1. Europa Clipper telecommunication system block diagram.

#### References:

- [1] D. Srinivasan, C. Sheldon and M. Bray, "Telecommunications systems for the NASA Europa missions," 2017 IEEE MTT-S International Microwave Symposium (IMS), Honolulu, HI, USA, 2017, pp. 394-397
- [2] Haskins, Christopher B. and Wesley P. Millard. "Multi-band software defined radio for spaceborne communications, navigation, radio science, and sensors." 2010 IEEE Aerospace Conference (2010): 1-9.

Excel Link Budget Table



ViaSat-3  
1Tbps capacity/satellite constellation

## Further Reading

- Systems Engineering for Telecom Subsystems
  - Yuen, J. H. (Ed.). (1983). **Deep Space Telecommunications Systems Engineering**. Springer US. <https://doi.org/10.1007/978-1-4757-4923-6>
  - Fortescue, P., Swinerd, G., & Stark, J. (Eds.). (2011). **Spacecraft Systems Engineering**. Wiley. <https://doi.org/10.1002/9781119971009>
  - Maral, G., Bousquet, M., & Sun, Z. (2020). **Satellite Communications Systems**. Wiley. <https://doi.org/10.1002/9781119673811>
- More theory on communication systems w.r.t spacecraft
  - Liu, J. (2015). **Spacecraft TT&C and Information Transmission Theory and Technologies**. In Springer Aerospace Technology. Springer Berlin Heidelberg. <https://doi.org/10.1007/978-3-662-43865-7>

- **Consultative Committee for Space Data Systems (CCSDS) standards**

- CCSDS 131.0-B-5      TM Synchronization and Channel Coding
- CCSDS 231.0-B-4      TC Synchronization and Channel Coding
- CCSDS 232.0-B-4      TC Space Data Link Protocol
- CCSDS 132.0-B-3      TM Space Data Link Protocol

→ De facto standard for most commercial spacecraft and ground stations

- **Link budget information/State-of-the-art/Current systems**
  - <https://www.eoportal.org/>
  
- **ESA Ladybird guide to spacecraft communications**
  - [https://www.esa.int/Education/ESA\\_Academy/](https://www.esa.int/Education/ESA_Academy/)



European Data Relay System (EDRS) satellite  
Broadband LEO to GEO to GND relay link

**Thank you !**

Questions?

[hannes.bartle@epfl.ch](mailto:hannes.bartle@epfl.ch)

ELB037

# Space Environment Impact on Telecom Systems

- Mechanical
  - Vibration
    - General Electronics
    - Workmanship errors
    - RF Connectors
  - Shock
    - Ceramic components (quartz crystals, SAW filters, LTCC components)
- Radiation
  - Digital electronics (TID/SEE)
  - RF components
    - Solid State Power amplifiers
    - Mixers
- Thermal
  - Frequency references
  - Low noise amplifiers

- Cost range TT&C subsystem
  - LEO New space (CubeSat Quality)
    - 5-10kEUR
    - 6-10 months lead time
  - LEO New Space (High Quality)
    - 50k-200kEUR
    - 12-15 months lead time
  - GEO
    - 0.5-2MEUR
    - 12-15 months lead time
  - DeepSpace
    - >5MEUR
    - >12 months lead time